

# NEWBURY

COLLECTION

EXPLORE LUXURY



91 NEWBURY STREET | 2,505 SF |

FOR RETAIL LEASING INFORMATION, PLEASE CONTACT:

Whitney Gallivan | Boston Realty Advisors | [wgallivan@bradvisors.com](mailto:wgallivan@bradvisors.com) | 617.850.9612

# 91 NEWBURY STREET

Lower & Street Level - 2,505 Square Feet

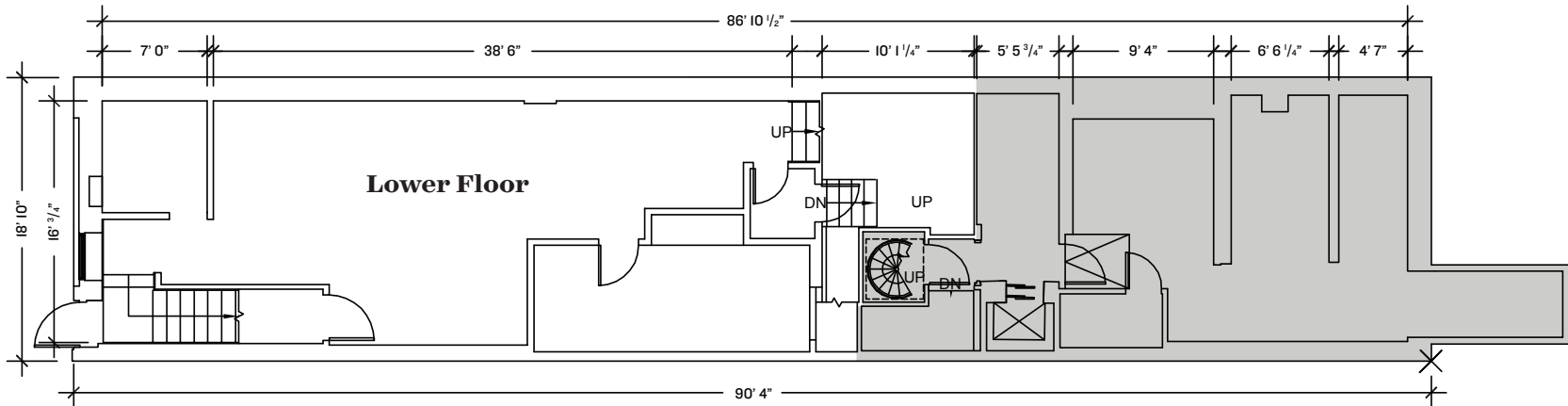
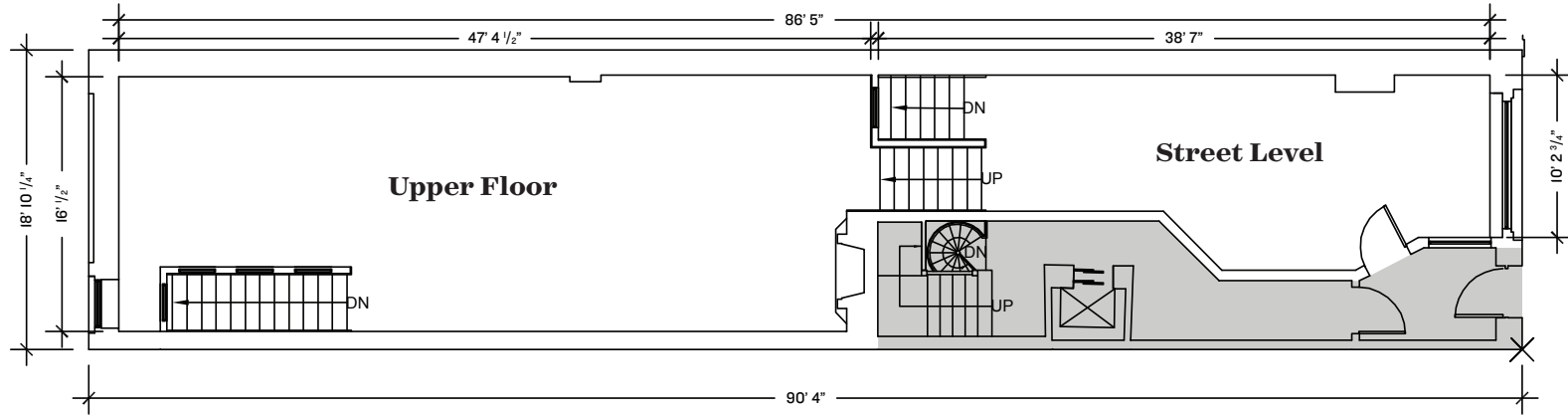

FOR RETAIL LEASING INFORMATION, PLEASE CONTACT:  
Whitney Gallivan | Boston Realty Advisors | [wgallivan@bradvisors.com](mailto:wgallivan@bradvisors.com) | 617.850.9612

[THENEWBURYCOLLECTION.NET](http://THENEWBURYCOLLECTION.NET)





# 91 NEWBURY STREET

Lower & Street Level - 2,505 Square Feet



## ABOUT THE SPACE

### APPROXIMATE SIZE

- › Street Level - 471 SF
- › Lower Floor - 1,069 SF
- › Upper Floor - 965 SF
- › Store Frontage - 13'

### LOCATION

- › Located on the 2nd block of Newbury Street between Berkeley & Clarendon Street

### SITE STATUS

- › Vacant - Formerly Axelle Fine Arts

### AVAILABILITY

- › Immediate

### COMMENTS

- › One of the rare street level entrances on Newbury Street
- › 8' High glass storefront
- › Ceiling Height
  - Street Level - 170"
  - Lower Floor - 92"
  - Upper Floor - 119"

THENEWBURYCOLLECTION.NET



# STREET GUIDE

AVAILABLE RETAIL SPACE  
NEWBURY COLLECTION PORTFOLIO

## 91 NEWBURY STREET

Lower & Street Level - 2,505 Square Feet

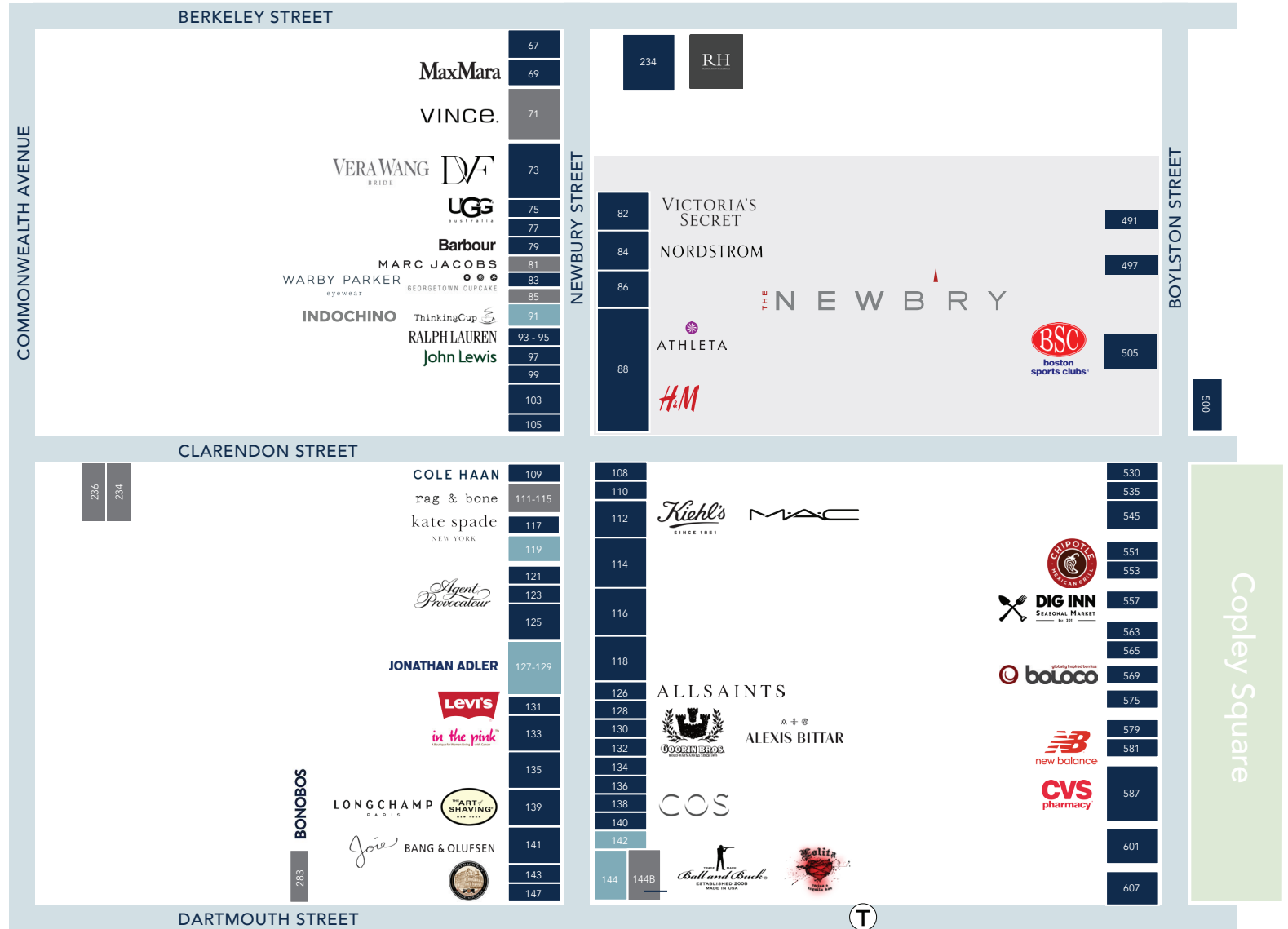

FOR RETAIL LEASING INFORMATION, PLEASE CONTACT:  
Whitney Gallivan | Boston Realty Advisors | wgallivan@bradvisors.com | 617.850.9612

[THENEWBURYCOLLECTION.NET](http://THENEWBURYCOLLECTION.NET)

